



Installation Instructions

8658 – SS Fiamma and ARB Awning Brackets (Pair)

- **Component/Subassembly Item List:**

Part Number:	QTY:	Description:
8659	2	Main Bracket- Black Hammertone Powder Coat
8660	2	Outer Gusset Bracket - Black Hammertone Powder Coat
8661	2	Inner Pinch Bracket - Black Hammertone Powder Coat
8662	1	Hardware Kit
2955	1	6" x 6" 3M Paint Protection Film (not shown)



- **Hardware Kit Contents:**

Bag A: Bracket Mounting

- 2 - M6X1.0X20 Grd 10.9 Hex Bolt
- 2 - M6 SS Washer
- 1 - M6 Nutsert Tool
- 4 - M8x1.25x35 Carriage Bolt
- 4 - M8 Black SS Washer
- 4 - M8 Nylock Nut
- 4 - Aluminum Spacer

Bag B: Fiamma Specific HWR

- 4 - M6x16 SS Carriage Bolt
- 4 - M6 SS DIN Washer
- 4 - M6x1.0 Nylock Nut
- 2 - M5x.08x14mm Phillips Head Screw
- 2 - M5x.08-Nylock Nut



- **Required Tools/Supplies:**

- | | | |
|-----------------------------|--------------------|------------------------------------|
| 3/8" Ratchet | 3/8" Torque Wrench | Hand Drill |
| 10mm and 13mm - 3/8" Socket | Painters Tape | 13/64", 1/4" and 25/64" Drill Bits |
| 11mm or 7/16" Wrench | 5mm Allen Wrench | #2 Philips Head Screwdriver |
| 8mm Wrench | Isopropyl Alcohol | Some Tasty Jams |
| Scissors | Center punch | Your fav' Beverage and Buddy |
| Shop Vac | | |

Bracket Installation:

Step 1: Start by prepping the rain gutter ensuring there is no debris trapped in the area's where the brackets will be mounted (B and D Pillar). Clean the Pillar area where the mount will attach with some isopropyl alcohol. Put some painters tape on the lower portion of the pillar where the bracket will meet the van. This will help prevent inadvertently scratching the van during the following steps. **Note: If you have a pop top, go ahead and raise it to gain more clearance for the installation.**



Step 2: With the Van prepped, go ahead and pre-assemble the awning brackets as shown below, but leave the nuts loose. Note: if you have an earlier model van with the taller rain gutter you will need to assemble the brackets on the Van starting with the pinch tab.

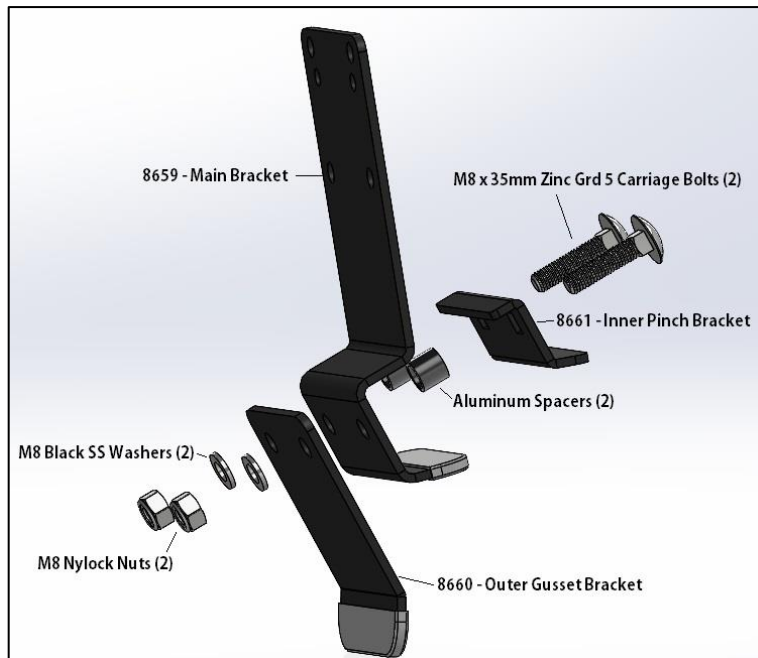

Step 2.1: (Fiamma Specific) If you're installing a Fiamma awning, you will need to attach the Fiamma supplied aluminum brackets to the Main Awning Bracket using the supplied M6

Carriage bolts, washers and nylock nuts. **Note:** Do not use the hardware supplied with the Awning however as the bolts may be excessively long and interfere with the pop top (if applicable).

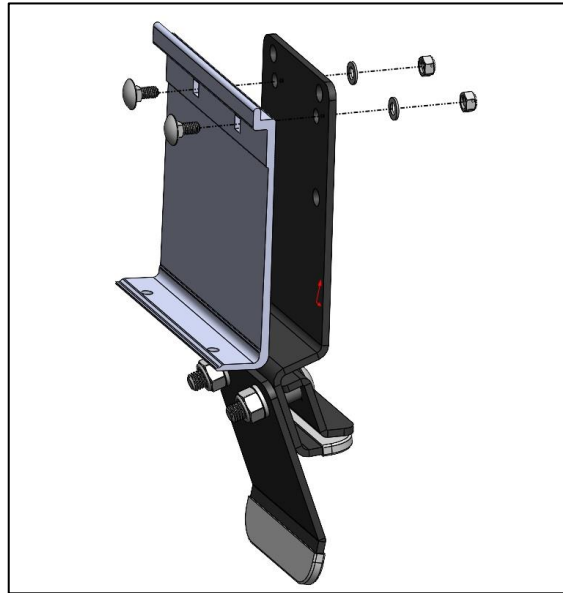

Step 3: Next, take the preassembled brackets and slip them over the rain gutter and center them at the B and D pillars. Using one hand, pull the brackets together to take out the slack and tighten both M8 Nylock nuts evenly using a 13mm Socket + ratchet. At this point just tighten the nuts enough to secure the bracket to the van.



Step 4: With the brackets secured to the van, use a small center punch to locate the lower hole in the outer gusset bracket as shown. Then use a 1/4" drill bit to drill through the plastic protector and into the Van.



Step 5: Next, remove both brackets from the van (leave them assembled if possible) and set them aside. Now using a 25/64" drill bit, enlarge the holes. Carefully deburr the holes and touch up the edges with some paint to prevent corrosion.



Step 6: Utilizing the provided nutsert tool (or a handheld nutsert tool if you have one), install the M6 Nutserts. Hold the brass nut with a 7/16" wrench or set of vice grips and insert the rivet

nut in the hole. While holding the nut tight to the Van, tighten the Allen head bolt using a 5mm Allen wrench to compress the nut to the sheetmetal. If the hole is too tight you can chase the hole using the 3/8" bit while slightly rotating the drill. **It is okay if the hole is slightly undersized requiring a slight tap from a hammer to get the Rivnut inserted into the hole. This will further prevent the Rivnut from spinning.**

Note - For the tool to work properly, it will need to be set up with the bolt, flat washer, brass nut, lock washer and rivet nut; in that order. This will prevent the rivet nut from spinning while tightening.



Step 7: Remove the painter's tape and cut the 6 x 6" piece of 3M paint protection film in half using a pair of scissors. Starting at the back of the rain gutter, carefully wrap from the back of the rain gutter down to the pillar. Try to keep the film as tight to the surface and centered on the pillar as possible when wrapping. The B pillar will require a 3 x 6 piece of film, while the D pillar will require more trimming to better conform to the shape of the pillar. Using a center punch, press into the protection film over the Rivnuts in order to make a hole for the bolt.



Step 8: Reinstall the awning brackets while leaving both Nylock nuts loose. Install the M6 bolts w/washer into the lower holes and leave them finger tight. Then proceed to tighten the M8 Nylock nuts down evenly and torque to 200 in/lbs. Then tighten and torque the M6 Bolts to 80 in/lbs.



Step 9: Mounting the Awning (Fiamma) - With the help of a buddy, carefully lift the awning onto the bracket's channel mount and position the awning so that it is maxed out on the rear mounting bracket. Once you have the awning positioned correctly, go ahead and fully extend the awning and set the legs to support the canvas.



Front Bracket: Using a sharpie, put a center mark centered on the mounting bracket, and in the middle of the lower awning channel. Using a 13/64" drill bit carefully drill through all 3 components. **Take your time to prevent drilling into the van!** Deburr the holes and vacuum up any shavings. Using the supplied M5 Phillips head screws, and Nylock nuts, install one into the drilled hole and tighten. This will fully secure the awning to the bracket



Rear Bracket: As for the rear drill location, put a mark centered on the lower channel, and offset to the left of the awning hinge by roughly ½". Repeat the drill process and install the remaining M5 Screw and Nylock nut.

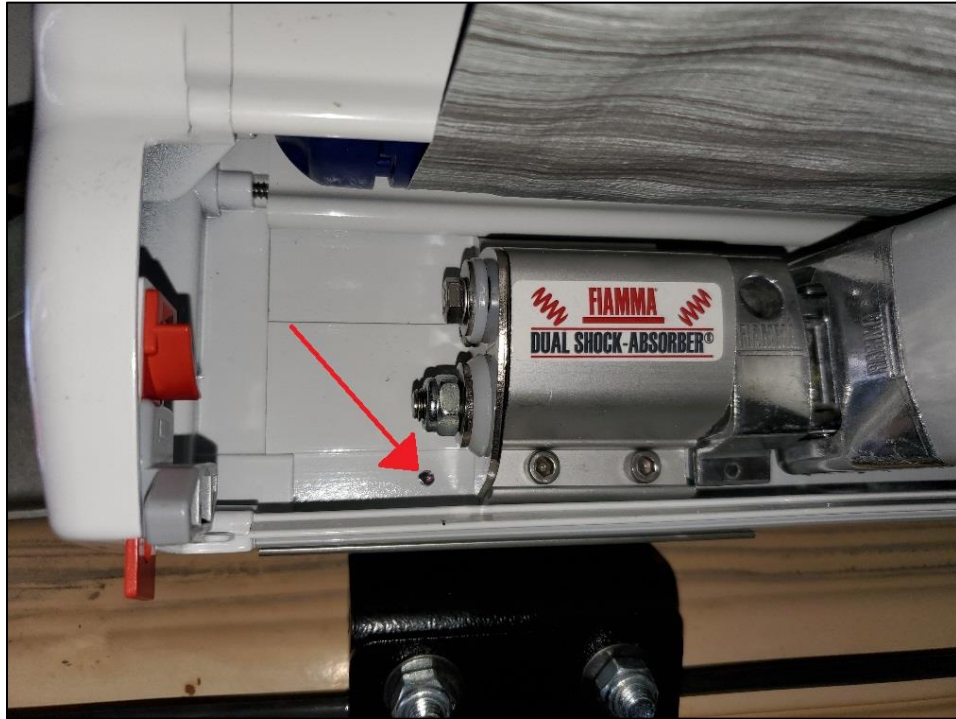

Step 9.1: Mounting the Awning (ARB) - Using the supplied hardware that is included with the ARB awning, slide the (6) M6 bolts into the T channels with 4 on the top side channel and 2 on the bottom channel. The Brackets have an additional hole as well to allow for 4 bolts per bracket if desired. With the help of your buddy, carefully lift the awning and align the bolts to fit onto the brackets. Slide the awning to the desired position (Typically centered on the brackets) and secure with the (6) Nylock nuts included with the awning.

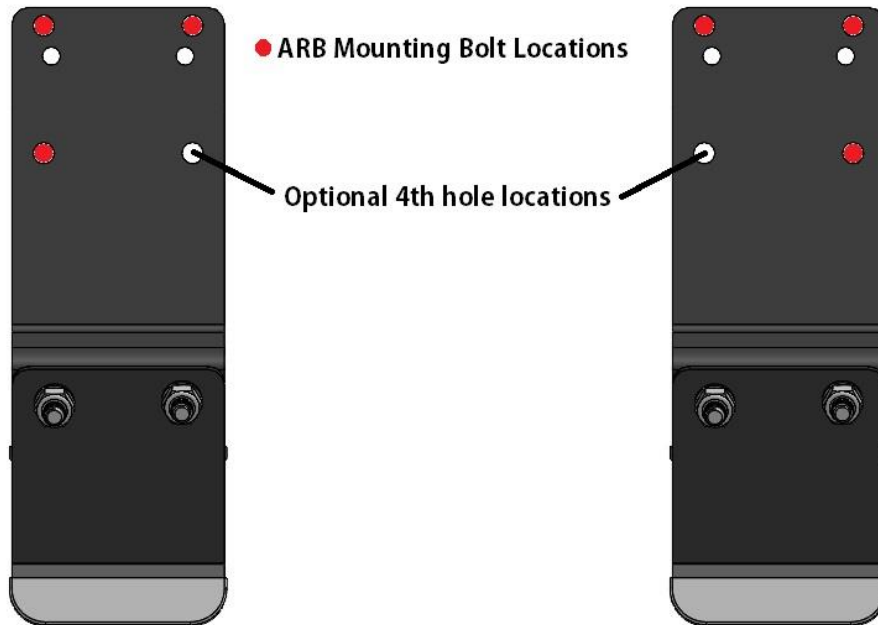

Disclaimer:

The end-user of this product assumes all responsibility for the use or misuse of this product. Neither Van Cafe nor Rocky Mountain Westy shall be held liable for any damage to person or property.

CALIFORNIA PROPOSITION
⚠ 65 WARNING ⚠

WARNING: This product contains chemicals known to the State of California to cause cancer and birth defects or other reproductive harm.

For more information: www.P65Warnings.ca.gov